



# Voith TurboCool VSD Fluid Coupling For Natural Gas Compressor Cooling Fan Drives

Gas / Electric Partnership

Feb. 9 & 10, 2011

## Typical Problems with Engine Driven Cooling Fans

- High noise levels due to full speed fan operation
- Hydrate condensation due to over cooling
- Bi-annual maintenance required to re-pitch fans
- Excessive parasitic power losses to drive fan at full speed
- Unscheduled shut downs due to over / under cooling



## Typical Problems with Engine Driven Cooling Fans



- Torsional problems in fan drive train
- Shock loading to fan during sudden engine stops

## **Solution: Variable Speed Fan Control with Voith TurboCool Drive**

### **Voith VSD Coupling Features:**

- **Cast aluminum, self supported housing**
- **Foot Mounted Assembly**
- **Closed loop internal oil circuit (no external oil connections)**
- **Heavy duty input & output shafts for pulley drive or direct couple**
- **Integral oil to water cooler (uses aux. water circuit)**
- **Uses instrument gas or compressed air to control speed**
- **Variable speed control down to 25% speed!**

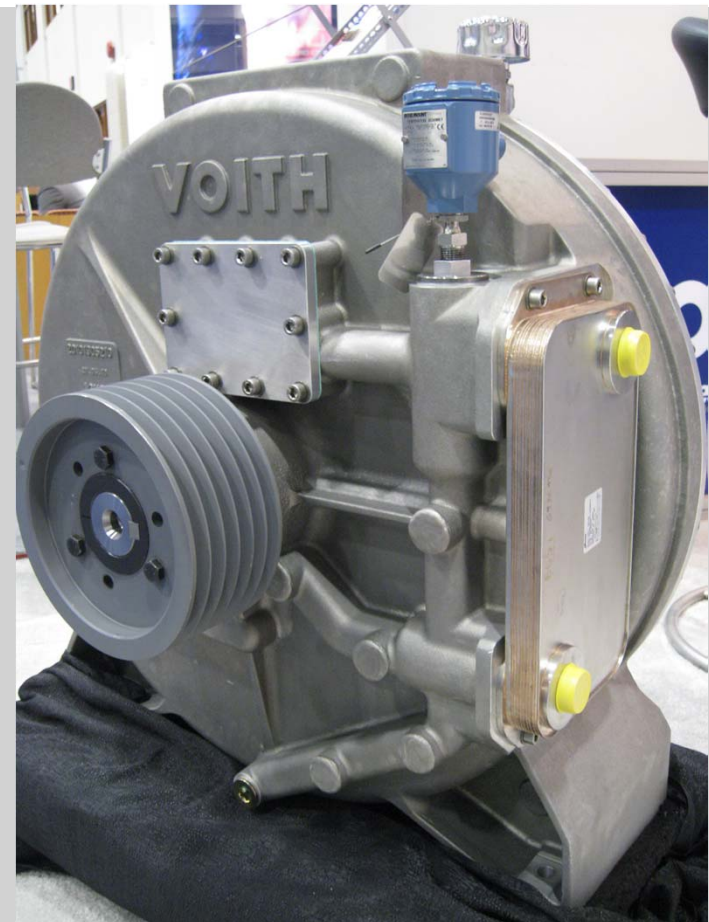

# Voith TurboCool Coupling Highly Integrated Cooling Circuit Design

View – Output Shaft

Note: All internal oil channels for closed loop filling & cooling control!

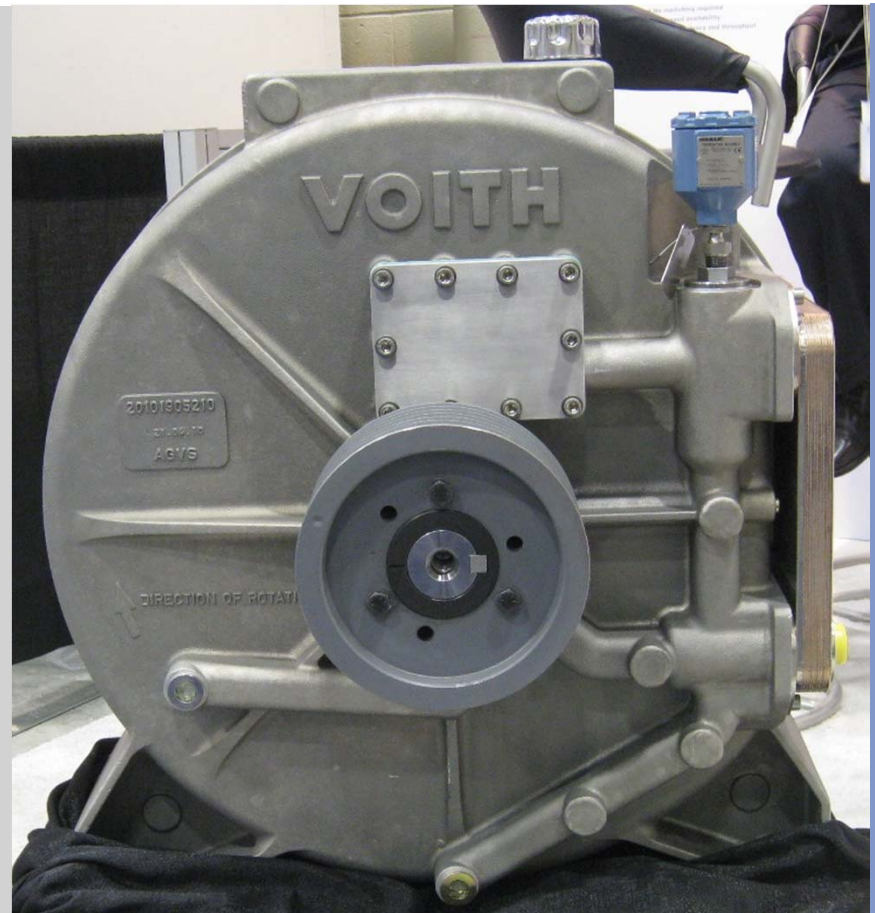

# Voith TurboCool Coupling Flexible Input & Output Design

Model 435 Prototype  
Unit

Side View with QD  
mount sheaves rated  
for up to 120 HP @  
1200 RPM

Input  
shaft



Output  
shaft

# Voith TurboCool Coupling Prleiminary Power Chart

Voith preliminary power chart				
Fan Power [hp]	1,000 rpm	1,200 rpm	1,400 rpm	1,600 rpm
20	Size 375*		Contact Voith	
30	Size 375*	Size 375*	Contact Voith	
40	Size 435	Size 375*	Contact Voith	
50	Size 435	Size 375*	Size 375*	Contact Voith
60	Size 435	Size 435	Size 375*	Contact Voith
70	Size 435	Size 435	Size 375*	Size 375*
80		Size 435	Contact Voith	Size 375*
90		Size 435	Contact Voith	Contact Voith
100		Size 435	Size 435	Contact Voith
110		Size 435	Size 435	Contact Voith
120		Size 435	Size 435	Contact Voith
130			Size 435	Contact Voith
140			Size 435	Size 435
150				Size 435
160				Size 435
170				
180				

# Fan Torque & Power Curves vs. Speed

Fluid Coupling Losses for Variable Speed Operation of Centrifugal Load Applications

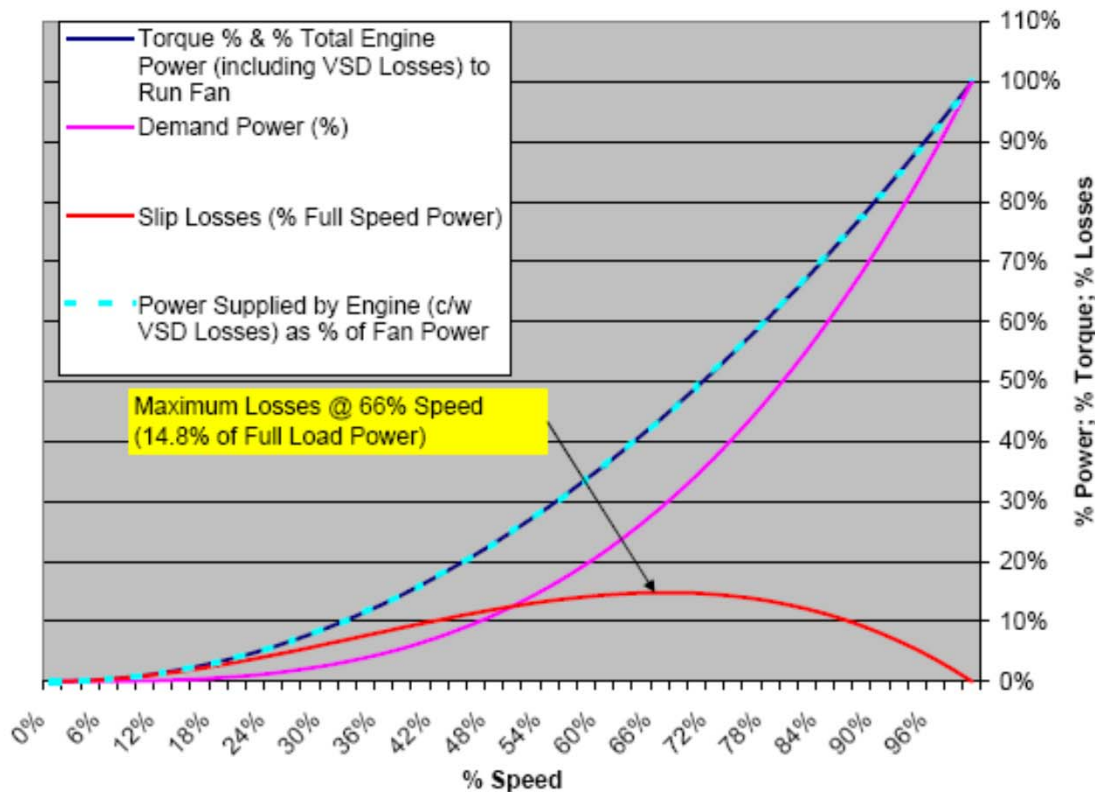

- The graph shows the fan torque, power and VSD losses vs fan speed.
- Note that the total engine power needed to drive the fan, including the VSD losses, is superimposed on the fan torque curve.

# TurboCool : Proposed Controls for **Prototype** Units

## Proportional Valve Solution (compressed air)

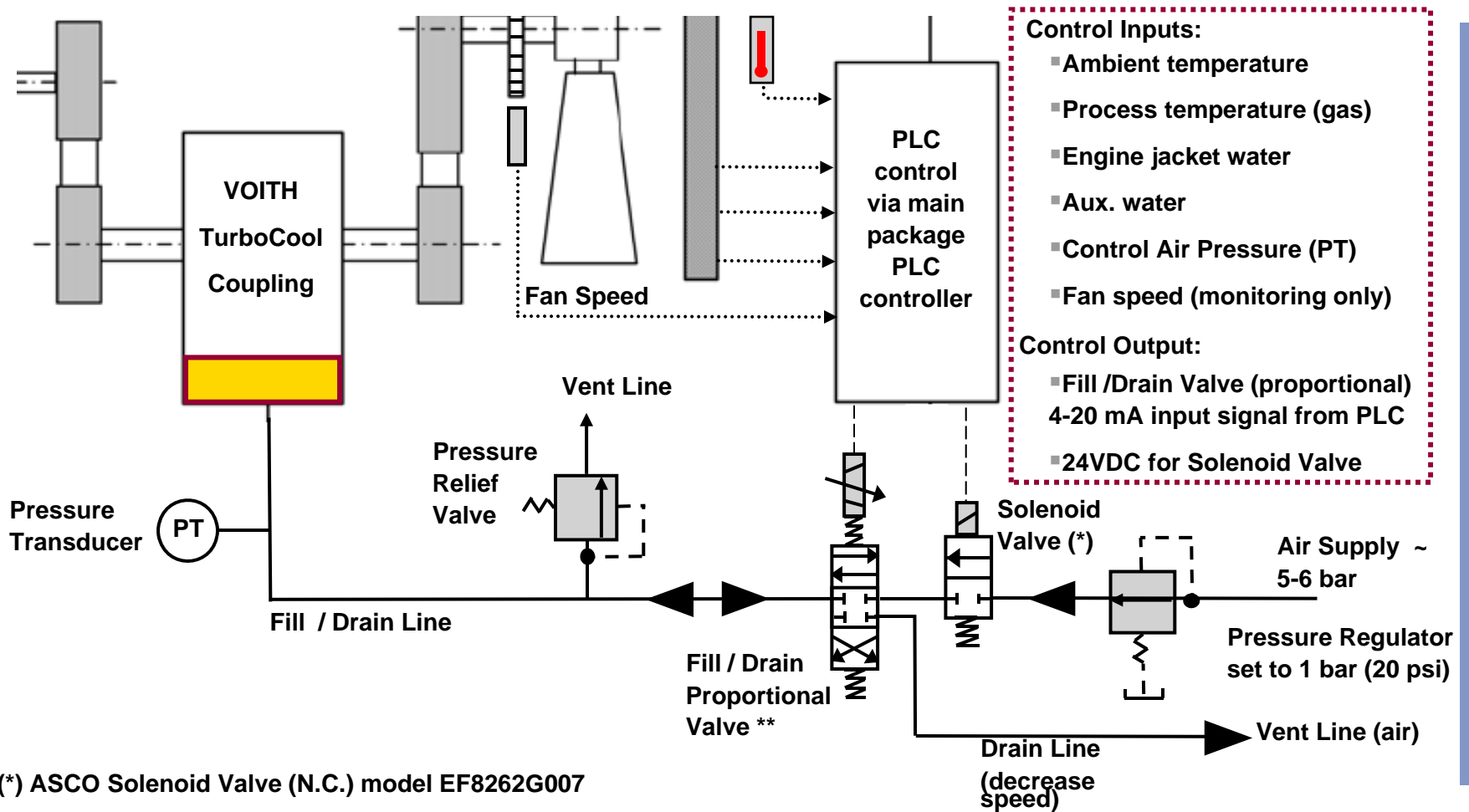

(\*) ASCO Solenoid Valve (N.C.) model EF8262G007

(\*\*) Fisher i2P-100FX or equal (model 846; model 546)

# Annual Fan Power Savings > Gillette, WY Based on Average Annual Site Temperature

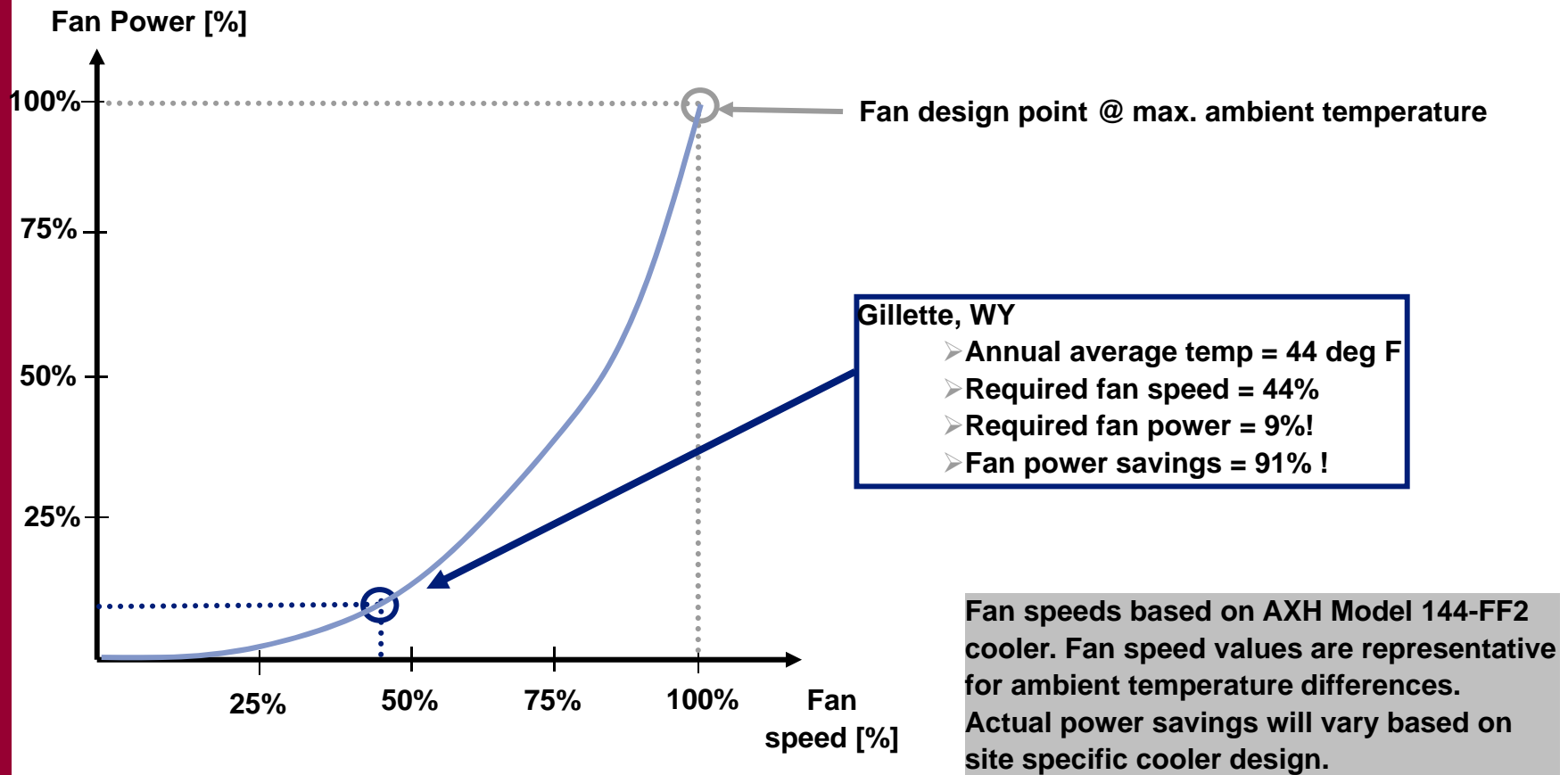

# Annual Fan Power Savings > Calgary, Alberta Based on Average Annual Site Temperature

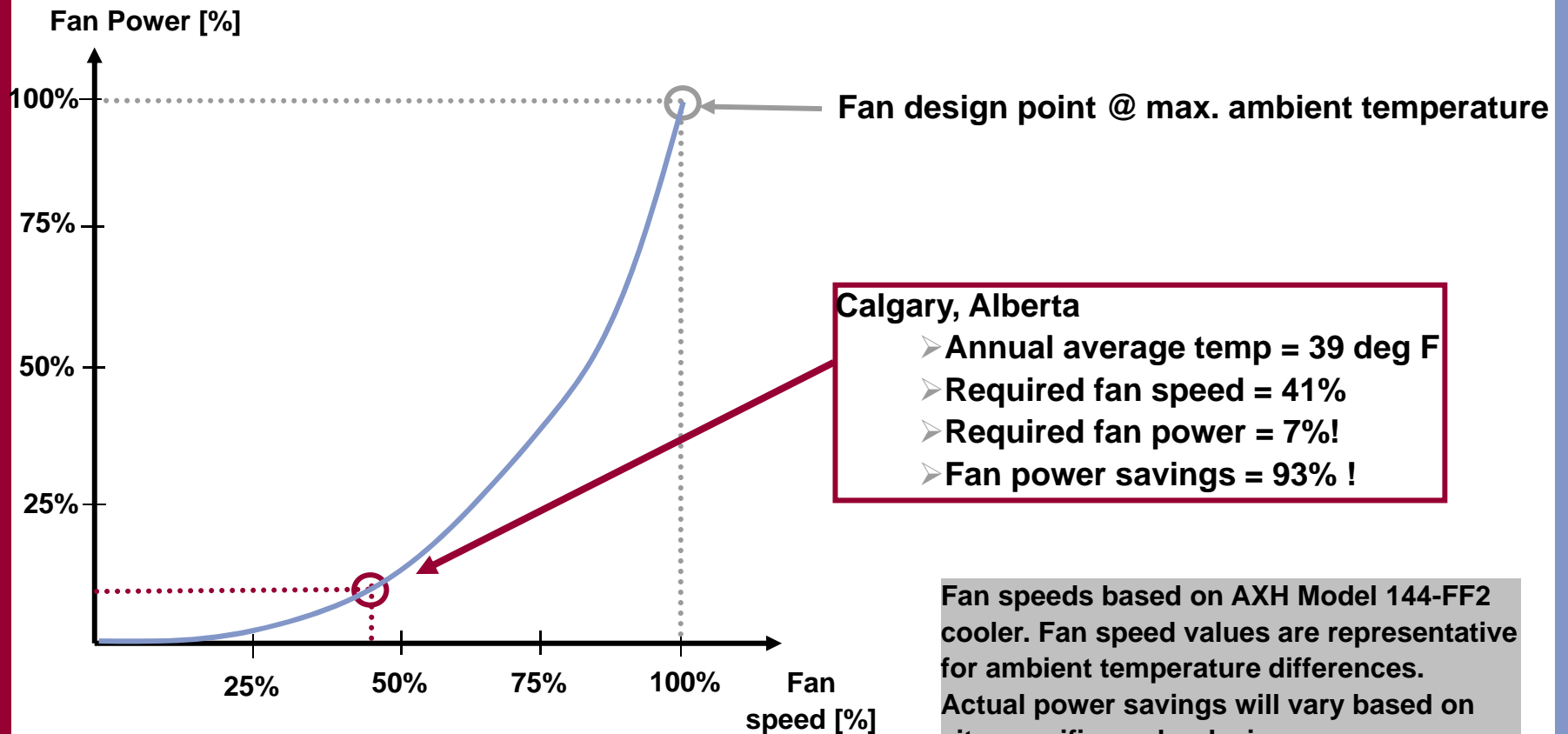

# Annual Fan Power Savings > Pittsburgh, PA Based on Average Annual Site Temperature

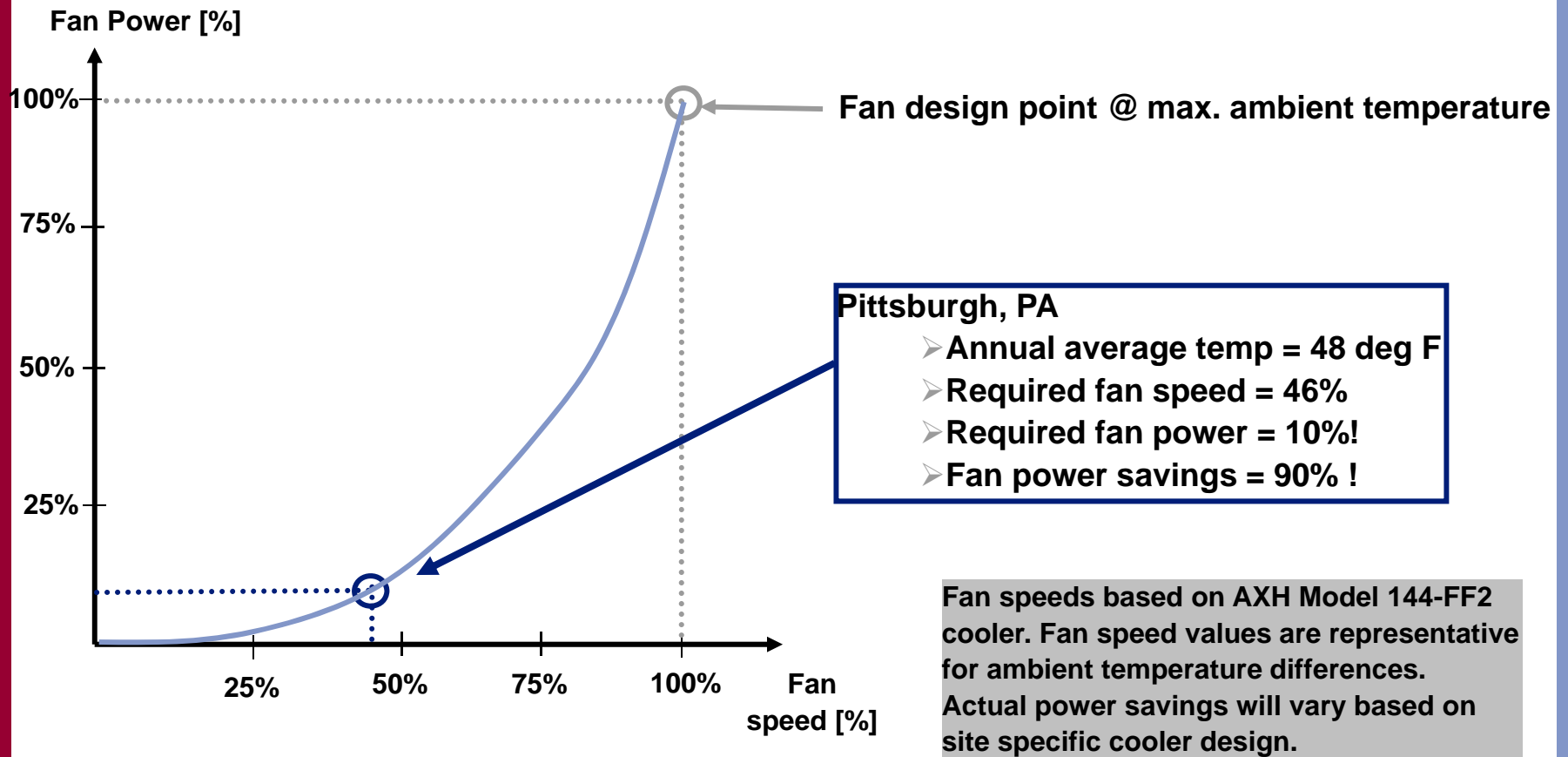

# Annual Fan Power Savings > Pittsburgh, PA Based on Average Annual Site Temperature

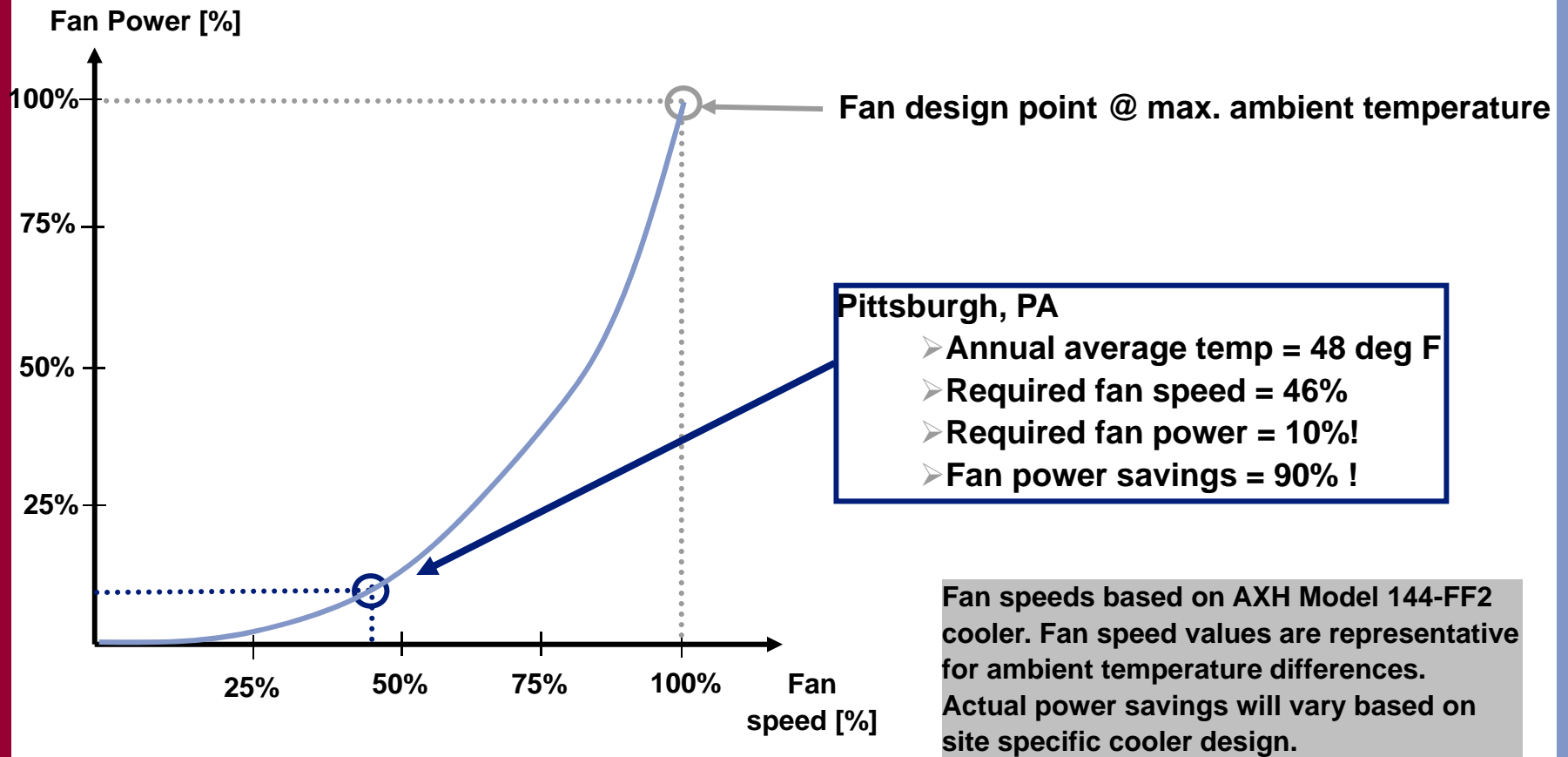

## Benefits of VSD : Reduced Fan Noise

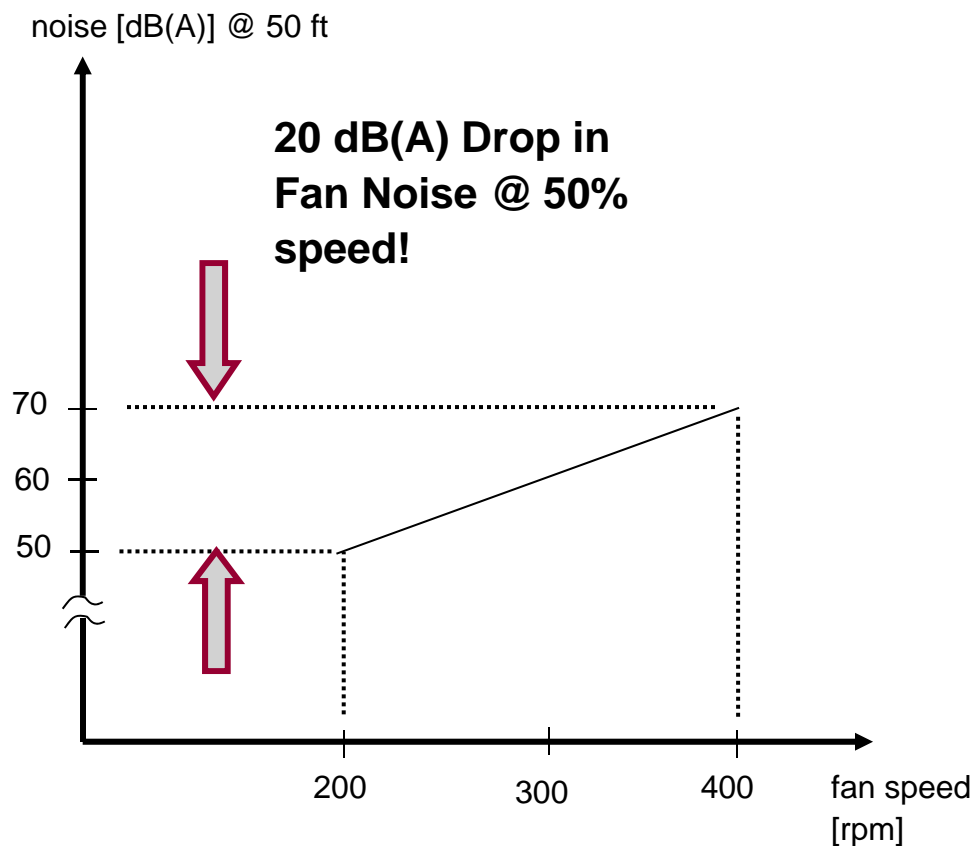

- Noise level drops with lower fan speed.
- See example on the left. (75 HP cooler fan – 10 ftØ)
- Allows for greater flexibility for installation location in sensitive areas
- Many noise regulations have lower noise level restrictions at night when cooler temperatures allow the fan to run at reduced speed.

## Benefits of VSD : Prevents Overcooling & Under cooling

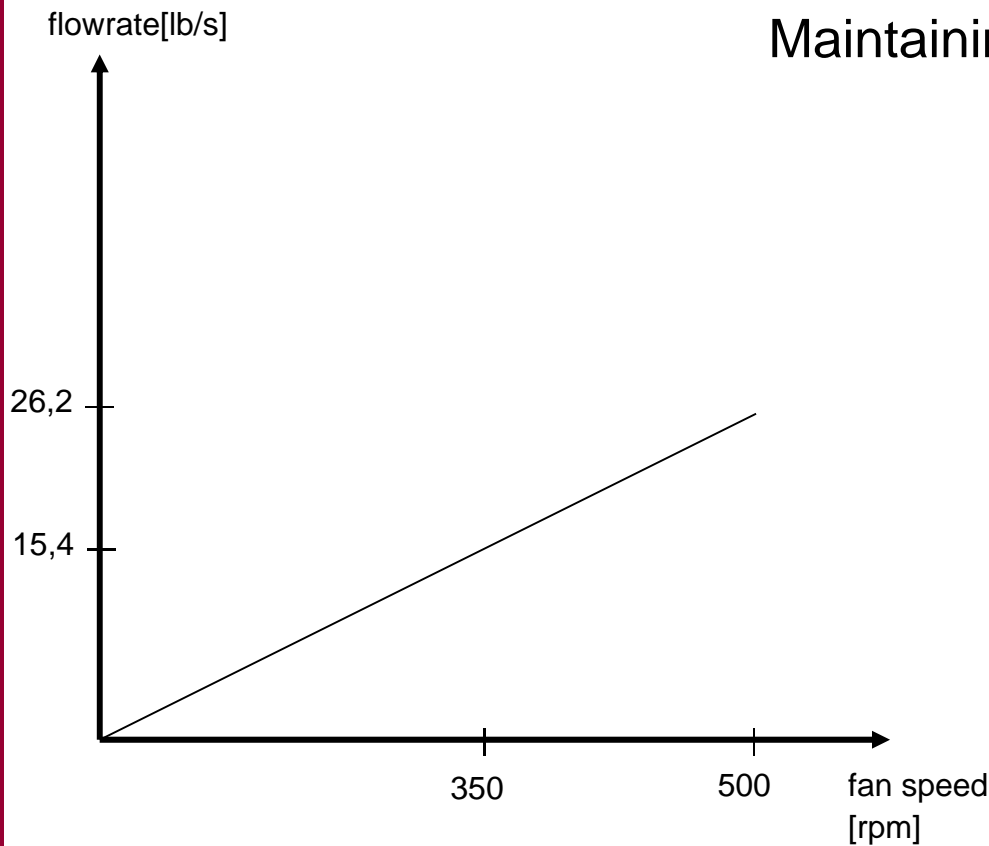

Maintaining the correct cooling provides:

- optimizes drive system efficiency.
- eliminates condensing hydrates and freezing of products from gas steam.
- prevents unscheduled shut down of compressor package during unexpected weather conditions

## Benefit of VSD : Increased Gas Production Possible !

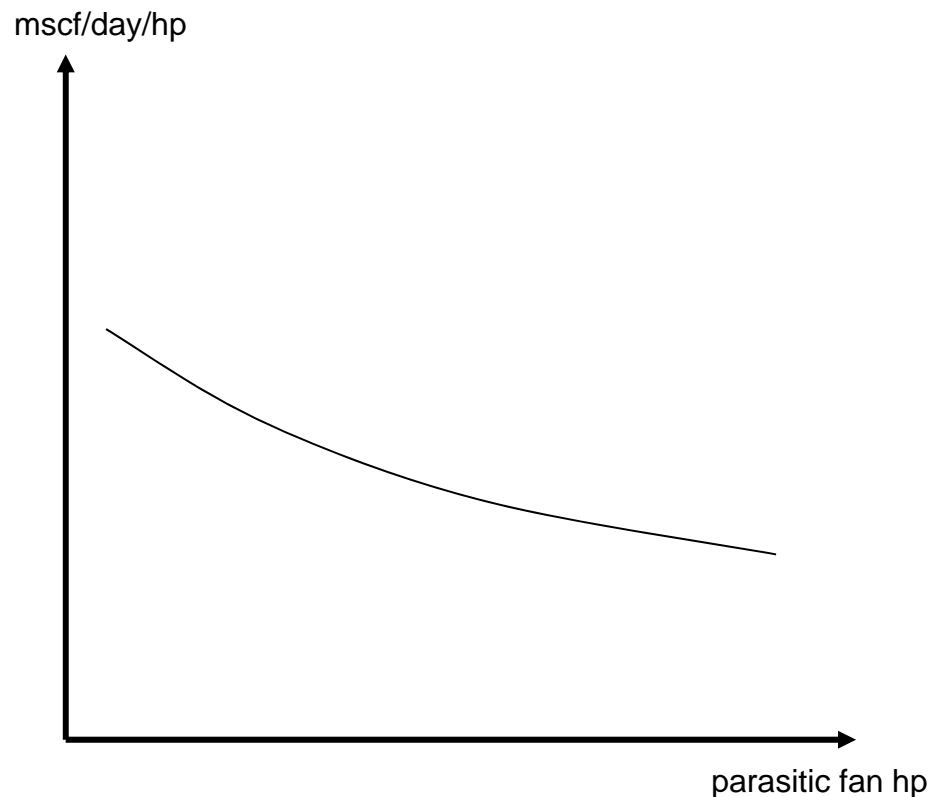

- Reducing the power demand from the fan means additional power is available for gas compression.
- Typical cooling fan drives absorb ~ 4% engine power. Most installations would only require less than 1% engine power as a yearly average!
- The extra 3% engine power can be used to compress gas!

## Benefit of VSD : Reduced Fuel Consumption

BTU/hr Fuel Gas

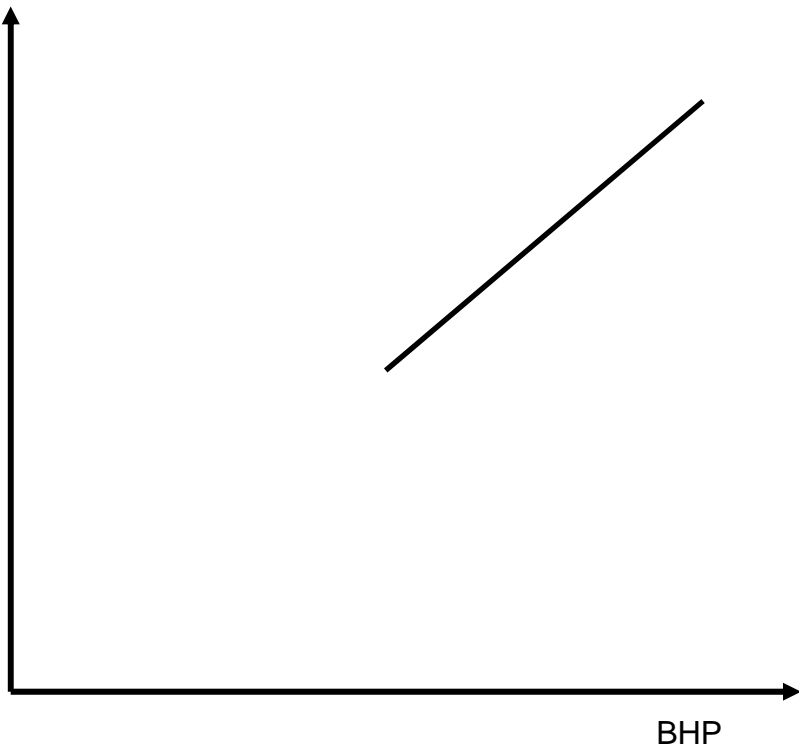

- Fuel consumption is proportional to load.
- Typical gas compressor fan drives are rated for 4% of total engine power.
- Most packaged compressor engines could achieve ~ 3% savings of fuel on an annual basis.
- Reduced fuel = **reduced CO<sub>2</sub> emissions!**

# TurboCool Mount Options

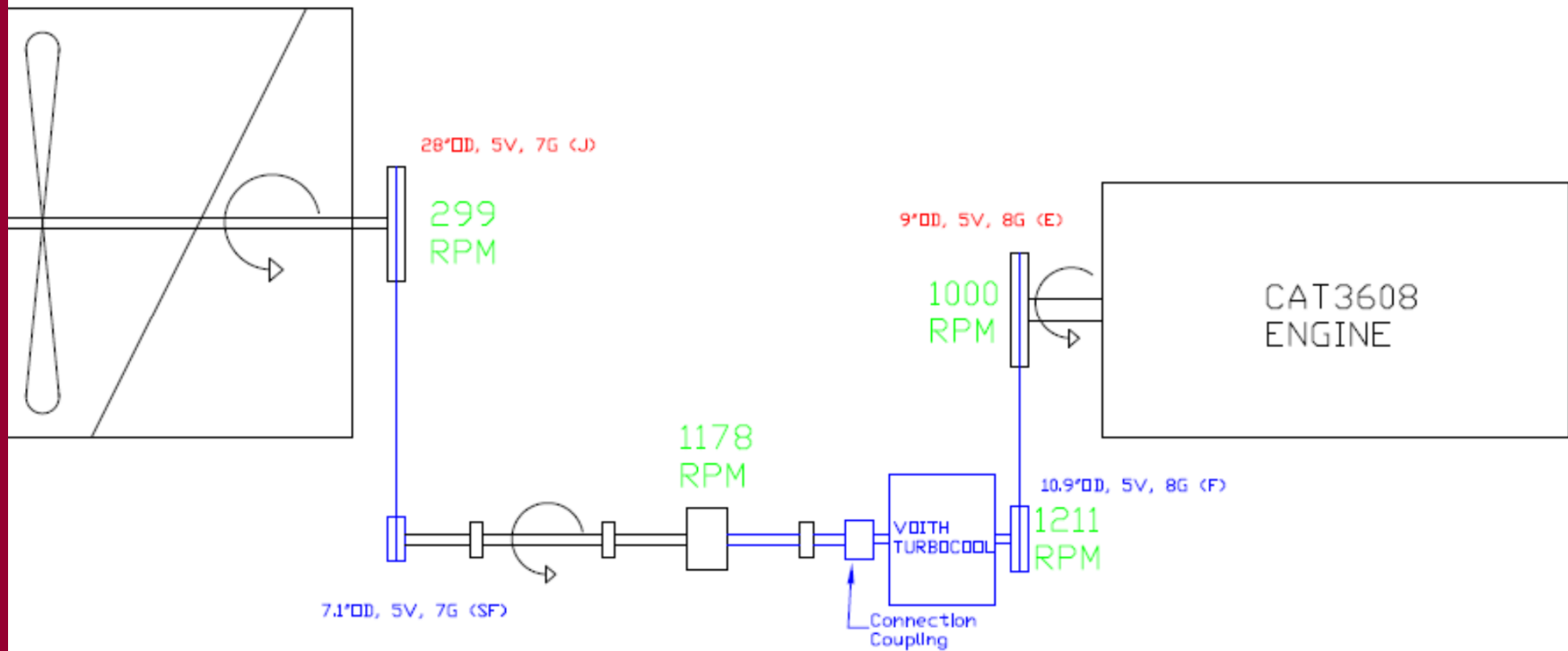

## Voith TurboCool Customer Benefits Summary

- Increases package efficiency
- Saves power which can be converted to increased production
- Reduces noise
- Saves Fuel / Reduces CO<sup>2</sup>
- Eliminates problems associated with over & under cooling
- Reduces maintenance cost
- Eliminates re-pitching fans
- Easy to retrofit

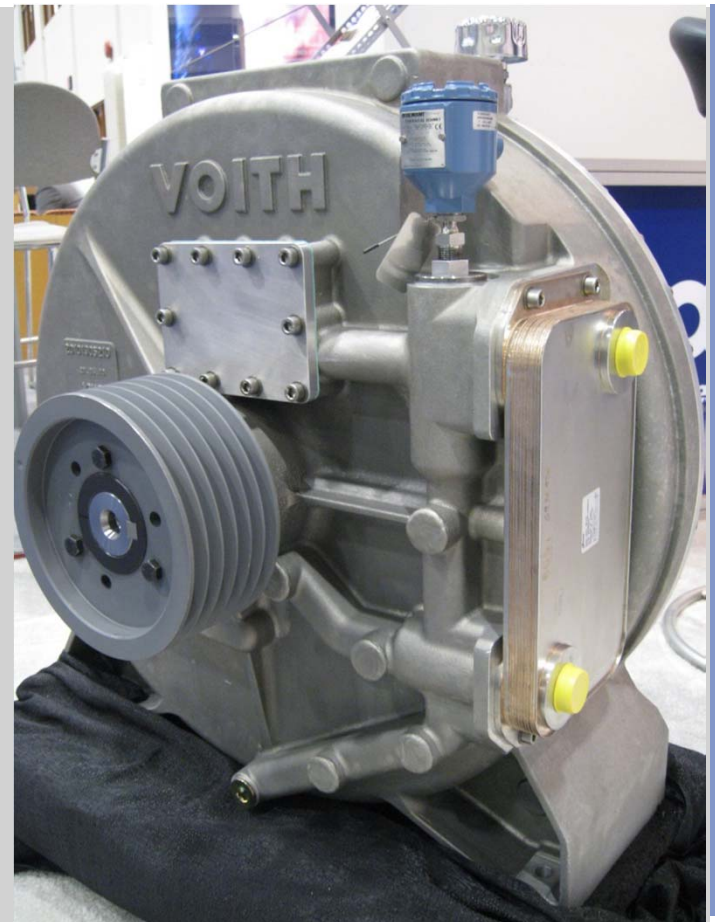



# VOITH

*Engineered reliability.*